

MERANO

Technical Sheet

Set 1

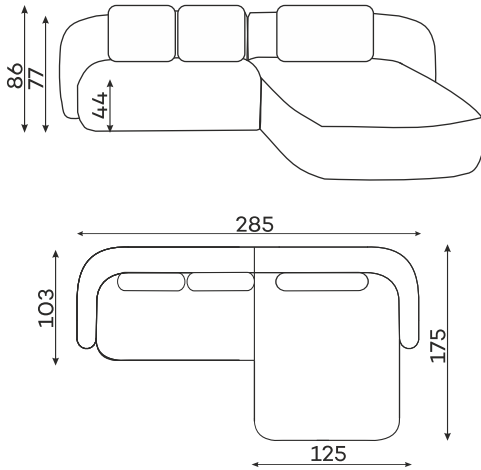

Collies

Dimensions tolerance of upholstered furniture +/- 4 cm.

Weight	kg net	kg gross	m3	L	S	H
collie 1	58	61	1,43	80	105	170
collie 2	62	65	1,82	80	130	176

Construction of the furniture

SEAT

Main structure, frame:

beech wood frame

Additional construction elements:

chipboard, softwood

Springs:

Zig Zag spring B

foam:

T30 foam

BACKREST

Main structure :

chipboard, softwood

Additional construction elements:

fiberboard, 7.5cm upholstery straps

Springs:

none

foam:

T25 + T30 foam

LEGS

Black plastic fi50 h25mm

Filled with:

with a mixed foam granulate
a mixture of polyurethane foam
and silicone granulate

Left side

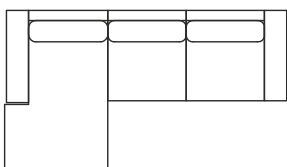

Right side

